

**Part Number:** BOX-2H-YVS11CL  
**Description:** Fleetliner Trunkbox  
**Fitment:** Yamaha V-Star 1100 Classic  
**Revision:** 1



Tools Required	Parts List
5mm Hex Key (allen head wrench) 1/4 x 20 Hex Key 13mm Open Wrench	1 #A00829 Trunk support bracket 1 #P10887 Right support bracket 1 #P10886 left support bracket 4 8mm x 1.25 x 25mm Chrome button head Allen screws 12 5/16" Chrome flat washers 4 Nylon Lock Nuts 6 1/4" x 20 x 1" Chrome button head Allen screws 6 1/4" x 20 Chrome flat washers 4 8mm x 1.25 x 70mm Chrome button head Allen screws

**NOTE:** We recommend the use of Loctite® or other threadlock material when assembling parts on your motorcycle.

1. Remove stock fender strut bolts, using a 5mm hex key (discard bolts). Be sure to hang onto the fender strut so it doesn't fall and scratch your bike. (Figure 1)



**FIG. 1**

2. Install Corbin's right support bracket (#P10887) onto the fender strut, using the supplied chrome flat washer between the fender and the bracket, then secure with the 8mm x 40mm chrome button head Allen screws (Figure 2). Use Loctite® and tighten to 12 ft. lbs.

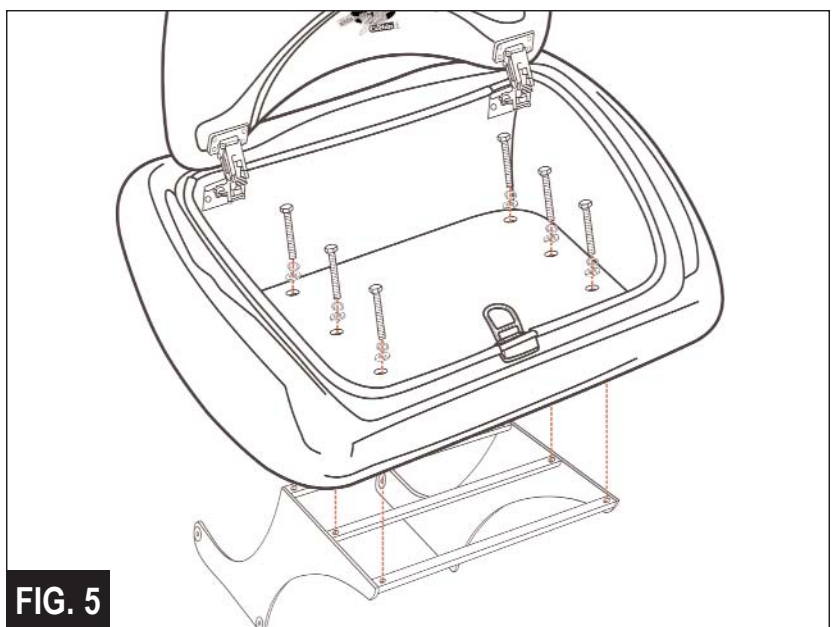

**FIG. 2**

3. Repeat this procedure on other side.

4. Now install the trunk support bracket. Place the left and right support brackets on the inside of the trunk bracket, line up the holes, then put one washer on a 8mm x 25mm chrome button head Allen screws (Figure 3), and secure with a flat washer and nylock nut (Figure 4). Tighten to 10 ft. lbs. and remember to use Loctite®.

5. Line up the six holes on the trunk to the holes on the mounting bracket. Secure with the supplied 1/4 x 20 x 1" button head Allen screws, lock washer and flat washer (Figure 5). Tighten to 6 ft. lbs.



Questions? Give us a holler...  
**800-223-4332**  
tech@corbin.com